

SPECS

PEAVEY ELECTRONICS

Impulse™ 652S Two-way System

SPECIFICATIONS

Enclosure:

Impulse™ 652S

Frequency Response:

60 Hz - 18 kHz

Low Frequency Limit (-3 dB point):

60 Hz

Usable Low Frequency Limit**(-10 dB point):**

50 Hz

Power Handling (*):

175 W Continuous (26.5 V RMS)

350 W Program

Sound Pressure Level at 2.83 V RMS**at 1 Meter Swept Sine Input in****Anechoic Environment:**

91 dB

Maximum Sound Pressure Level ():**

110 dB

Radiation Angle Measured at -6 dB**Point of Polar Response:**

500 Hz - 1.6 kHz:

Horizontal: 135° ± 29°

Vertical: 131° ± 25°

1.6 kHz - 5 kHz:

Horizontal: 115° ± 25°

Vertical: 117° ± 14°

5 kHz - 16 kHz

Horizontal: 115° ± 21°

Vertical: 102° ± 16°

Directivity Factor Ro (Q)**500 Hz - 16 kHz Median:**

3.7

Directivity Index (Di)**500 Hz - 16 kHz Median:**

5.6 dB

Transducer Complement:

One 6 1/2" shielded magnet woofer and
one 19 mm titanium dome tweeter

Box Tuning Frequency (Fbox):

55 Hz

Harmonic Distortion:

1/100 Power

2nd Harmonic: 100 Hz - 3.0%

1000 Hz - 0.7%

3rd Harmonic: 100 Hz - 0.8%

1000 Hz - 0.8%

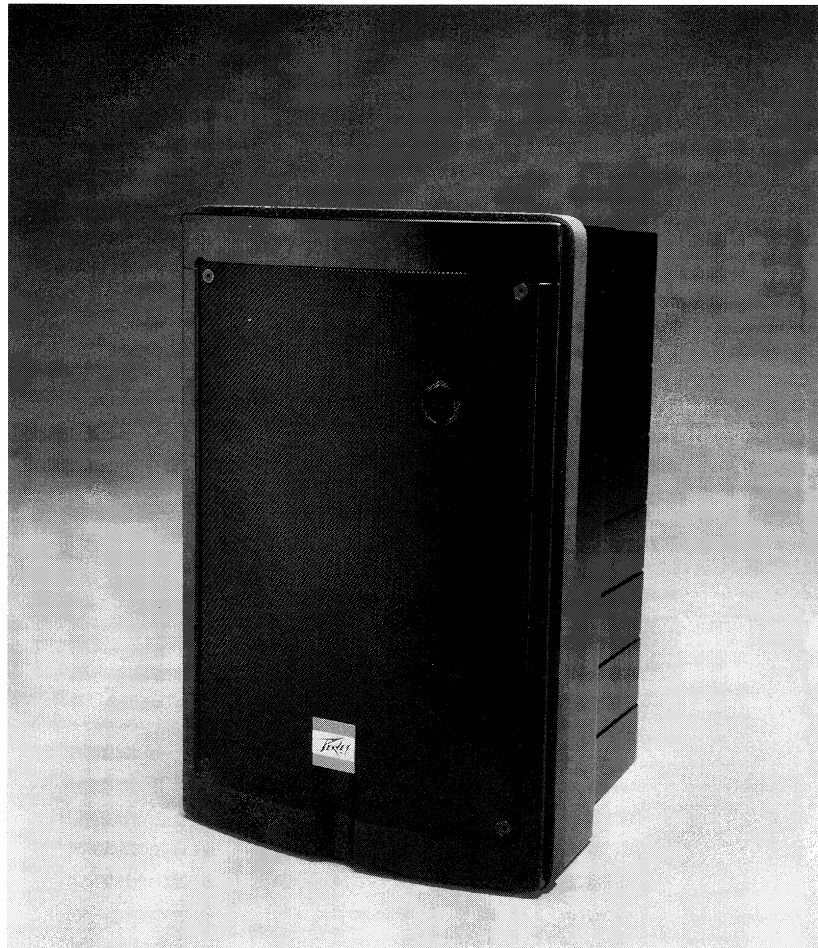

1/10 power

2nd Harmonic: 100 Hz - 11%
1000 Hz - 1.2%

3rd Harmonic: 100 Hz - 3%
1000 Hz - 1%

Electro-Acoustic Crossover**Frequency:**

4 kHz

Crossover Type:

Passive two-way internal

Electrical Crossover Slope:

12 dB/octave (2nd order) high and low
pass

Impedance (Nominal):

4 ohms

Impedance (Minimum):

3.6 ohms

Input Connections:

Push spring terminals

Enclosure Materials and Finish:

Molded black CALP plastic with matte
textured finish, with black perforated metal
grille

Mounting:

Locations on three surfaces: side, top, and
back; these mate with Peavey's
Versamount™ 35 mounting bracket

Dimensions:

10.25" W x 15.5" H x 9.88" D
(260 mm W x 394 mm H x 251 mm D)

Net Weight:

12 lbs. (5.5 kgs.)

Optional Accessories:

Versamount™ 35 wall mount bracket



FEATURES

- Two-way monitor design
- 6 1/2" high compliance woofer
- 19 mm titanium tweeter
- Shielded magnet structures
- Internal 12 dB/octave passive crossover
- Molded black plastic cabinet
- Weather resistant system
- Black metal grille
- Push spring terminals
- Twelve threaded inserts for mounting hardware
- Hi-fi sound character

* Power measured using a modified AES 2-1984 standard test (pink noise with 6 dB crest factor, bandwidth limited at 12 dB/octave from 40 to 5 kHz, for 2 hours).

** Maximum sound pressure level based on bandwidth limited power (See footnote on power measurement above).

DESCRIPTION

The Impulse™ 652S is a two-way monitor with a wide range response and high sensitivity for its size. The hi-fi sound character is due to the combination of a foam edge 6 1/2" woofer and a 19 mm titanium tweeter with built-in diffusion cap. The internal passive crossover has 12 dB/octave slopes to ensure good power handling while providing a smooth frequency response from 60 Hz to beyond 18 kHz.

The black molded plastic cabinet is weather-resistant, and a curved black metal grille protects the speakers. Installation is aided by the integral threaded inserts provided for mounting hardware (hardware optional) and the spring terminal inputs. These qualities offer versatility for use in video control monitors, background music, paging systems, meeting rooms, churches, and restaurant requirements. Offering an unobtrusive yet elegant appearance, the Impulse 652S has a "big sound" with hi-fi clarity and detail.

DIRECTIVITY

Beamwidth and directivity factors are derived from the -6 dB points from the polar plots which are measured in a whole space anechoic environment. These are specifications which provide a reference to the coverage characteristics of the enclosure. These parameters provide insight for proper enclosure placement and installation in the chosen environment. The blending of the components of the Impulse 652S exhibits a desirable beamwidth and directivity factor suitable for many sound reinforcement applications.

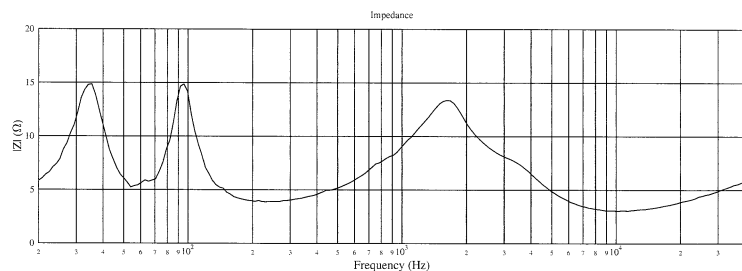
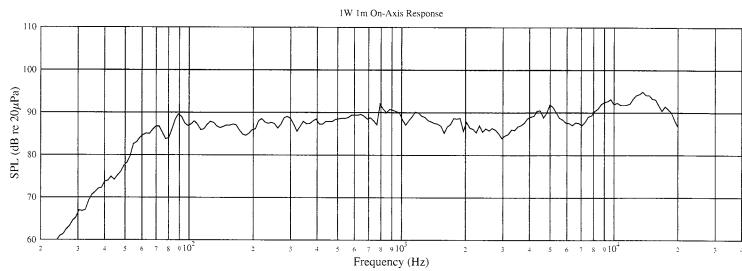

Polar Beamwidth vs Frequency Plot

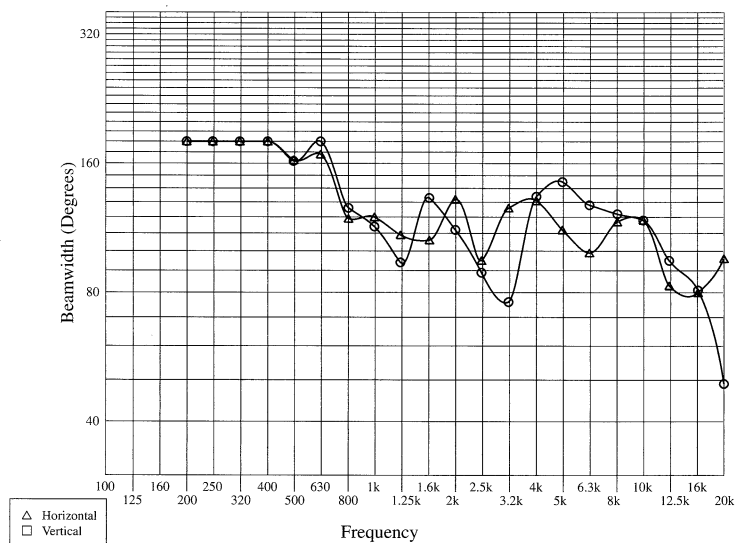

Directivity and Q plots

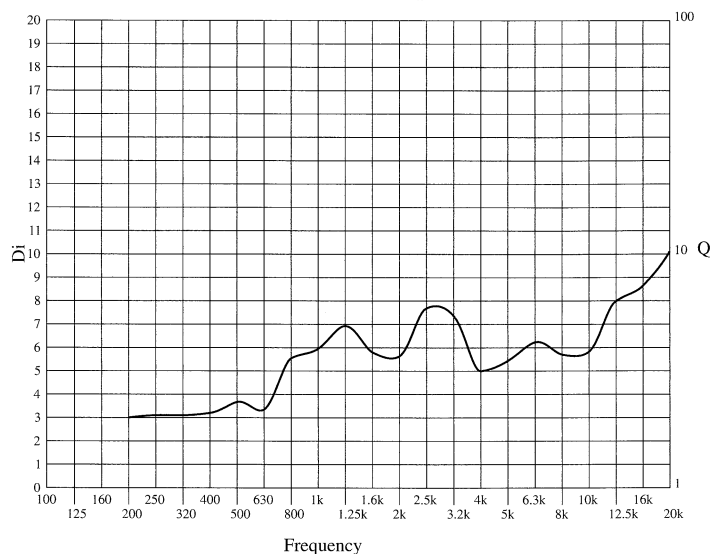

HORIZONTAL POLAR PATTERNS

6 dB per division

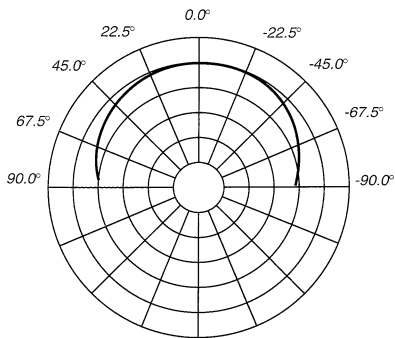

500 Hz

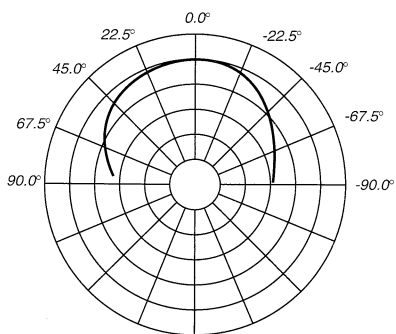

1 kHz

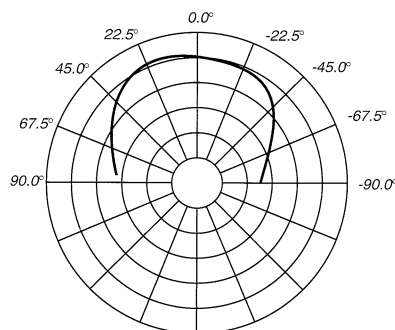

2 kHz

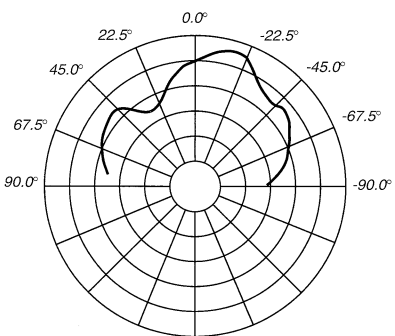

4 kHz

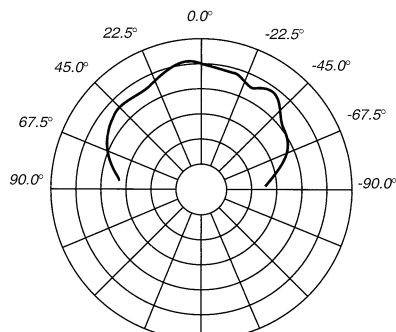

8 kHz

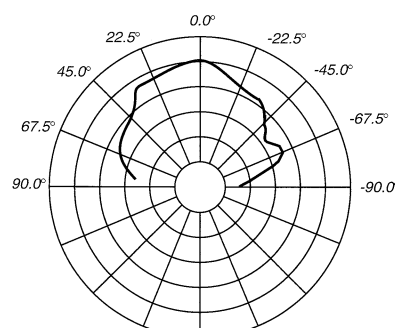

16 kHz

VERTICAL POLAR PATTERNS

6 dB per division

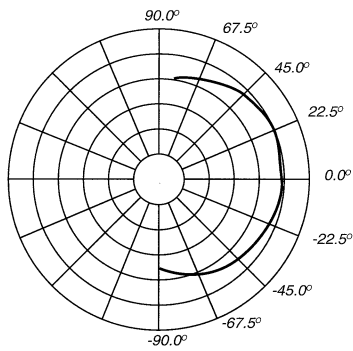

500 Hz

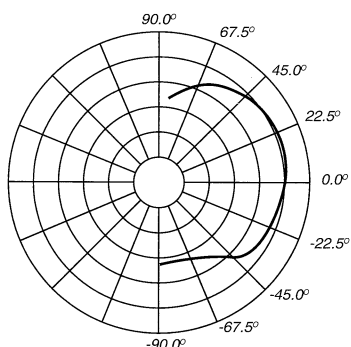

1 kHz

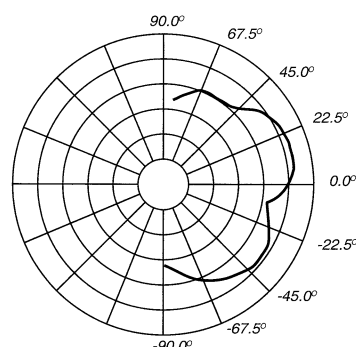

2 kHz

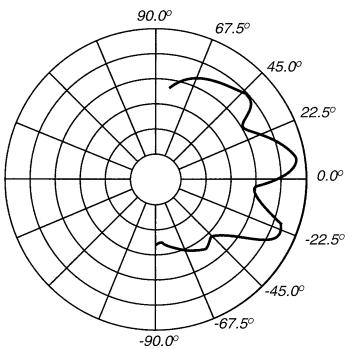

4 kHz

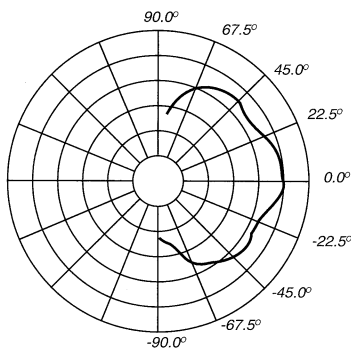

8 kHz

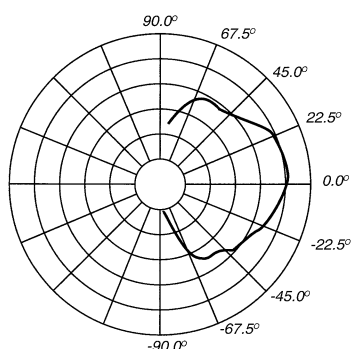

16 kHz

FREQUENCY RESPONSE

This measurement is useful in determining how accurately a given enclosure reproduces an input signal. The frequency response of the Impulse 652S is measured at 1 meter using a 2.00 V swept sine input. The selected drivers in the Impulse 652S combine to give a smooth frequency response from 60 Hz to 18 kHz.

POWER HANDLING

There are many different approaches to power handling ratings. Peavey rates this speaker system's power handling using a modified form of the AES Standard 2-1984. Utilizing audio band (40 Hz - 5 kHz) pink noise with peaks over four times the RMS level, this strenuous test signal assures the user that every portion of this system can withstand today's high technology music. The test signal contains large amounts of very low frequency energy, effectively simulating the frequency content of live music situations. The full measure of high frequencies in the test signal allows for exposure of the speaker system to

synthesized tone that may extend beyond audibility. This rating is contingent on having a minimum 3 dB of amplifier headroom available.

HARMONIC DISTORTION

Second and third harmonic distortion versus frequency is plotted at two power levels: 1/10 of rated input power and either 1/100 of rated input power or 1 watt, whichever is higher. Distortion is read from the graph as the difference between the fundamental signal and the desired harmonic. As an example, distortion that is 40 dB down from the fundamental signal is equivalent to 1% distortion.

MOUNTING

The Impulse 652S can be mounted using a Peavey Versamount 35 wall mounting bracket.

ARCHITECTURAL & ENGINEERING SPECIFICATIONS

The loudspeaker system shall have an operating bandwidth of 60 Hz to 18 kHz. The output level shall be 91 dB when measured at a distance of one meter with an input of 2.83 V. The nominal impedance shall be 4 ohms. The continuous power handling shall be 175 watts, maximum program power of 350 watts, with a minimum amplifier headroom of 3 dB. The nominal radiation geometry shall be 120 degrees in the horizontal plane and 115 in the vertical plane. The outside dimensions shall be 10.25" W x 15.5" H x 9.88" D. The weight shall be 12 lbs. The loudspeaker system shall be a Peavey model Impulse™ 652S.

ONE-YEAR LIMITED WARRANTY

NOTE: For details, refer to the warranty statement. Copies of this statement may be obtained by contacting Peavey Electronics Corporation, P.O. Box 2898, Meridian, Mississippi 39302-2898.



Features and specifications subject to change without notice.

Peavey Electronics Corporation 711 A Street / Meridian, MS 39301 / U.S.A. / 1-601-483-5365 / Fax: 1-601-486-1278